

4800L Polyethylene Pump Station

Model No BIA-ICON4800
 Depth 2110mm (excluding lid)
 Length 2280mm
 Width 1985mm
 Access cover 600mm diameter
 Approximate weight 195kg (excluding plumbing and pump)

Available in
 BIA-ICON4800 Tank only
 BIA-ICON4800 Tank with single free standing plumbing
 BIA-ICON4800 Tank with single plumbing and guide rails
 BIA-ICON4800 Tank with dual free standing plumbing
 BIA-ICON4800 Tank with dual plumbing and guide rails

Tanks are supplied as standard with polyethylene lids and are available with lid options as follows:
 > Class B > Storm Water grate

Risers are available as an optional extra (550mm).

Inlet plumbing to be installed by plumber on site.

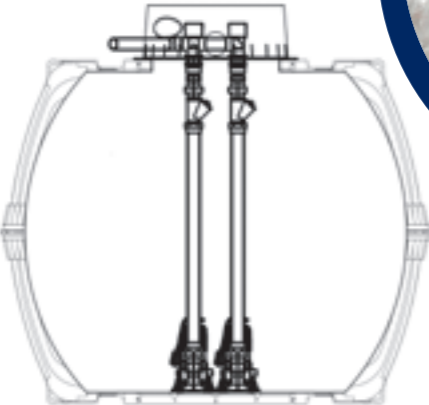

Applications
 Raw sewage Effluent
 Trade Waste Storm Water

6500L Polyethylene Pump Station

Model No BIA-ICON6500
 Depth 2390mm (excluding lid)
 Length 2390mm
 Width 2190mm
 Access cover 600mm diameter
 Approximate weight 230kg (excluding plumbing and pump)

Available in
 BIA-ICON6500 Tank only
 BIA-ICON6500 Tank with single free standing plumbing
 BIA-ICON6500 Tank with single plumbing and guide rails
 BIA-ICON6500 Tank with dual free standing plumbing
 BIA-ICON6500 Tank with dual plumbing and guide rails

Tanks are supplied as standard with polyethylene lids and are available with lid options as follows:
 > Class B > Storm Water grate

Risers are available as an optional extra (550mm).

Inlet plumbing to be installed by plumber on site.

Applications
 Raw sewage Effluent
 Trade Waste Storm Water

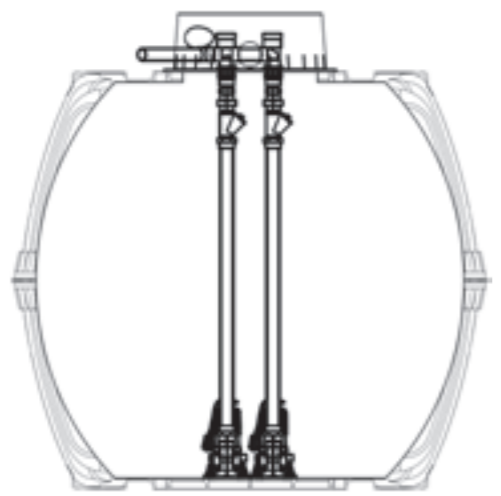

Lid options



Class B Grate

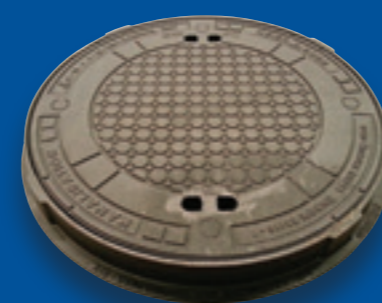

Class B



Class D

Control Panel

Single Pump Control
 SPC1 2.2kW
 SPC3 4kW, 11kW, 15kW



Dual pump control
 DPC1 2.2kW
 DPC3 4kW, 11kW, 15kW



Alarm

iAlarm High Level



WHITE INTERNATIONAL PTY LTD
 52-60 Ashford Ave Milperra NSW 2214
 PO Box 304 Milperra LPO NSW 2214
 Phone 02 9783 6000 Fax 02 9783 6001
 Customer Service Hotline 1300 783 601
 Email Sales: pumpsales@whiteint.com.au
 General info: info@whiteint.com.au
www.whiteint.com.au

WHITE INTERNATIONAL NZ LTD
 15G Kerwyn Avenue, East Tamaki
 Auckland 2013, New Zealand
 Phone 09 579 9777 Fax 09 579 7775
 Customer Service Hotline 0800 509 506
 Customer Service Faxline 0800 804 344
 Email Sales: sales@whiteint.co.nz
 General info: info@whiteint.co.nz
www.whiteint.co.nz



iCON Packaged Pump Stations



Introducing the Bianco iCON range of Packaged Pump Stations.

The iCON Packaged Pump Station is suitable for installation in various Domestic and Industrial Applications. Packaged Pump Stations are generally used in areas where gravity drainage to waste water services are not available. The iCON pump station is designed to withstand ground and water pressure when installed correctly and according to the installation instructions. It has smooth internal walls and an optimum collection area to aid in the removal of waste water and prevents smells and septicity.

Bianco iCON Series Pump Stations conform to Product Standard - AS/NZS 1546.1:2008 with certification available upon request. Other approvals have also been obtained in certain states which are also available upon request.

The Bianco iCON pump station is moulded in polyethylene. Installations with either single or dual pumps systems for Storm Water, Drainage or Sewage applications are possible. Plumbing options include free standing or guide rail installations depending on site requirements. The iCON Packaged Pump Station is supplied as standard with a Polyethylene Lid with the option of class B or class D lids available, depending on the size of the tank. Automated control of the system is possible through level input signals normally provided by means of float switches connected to a pump control panel (see page 6) and set at the required levels inside the tank. Options other than float switches are available upon request. Isolation valves and non-return valves are usually included in our packed pump stations but should be specified at the time of the quotation.



iCON Packaged Pump Stations | SPECIFICATIONS

600L Polyethylene Pump Station

Model No	BIA-ICON600
Depth	800mm (excluding lid)
Diameter	1200mm
Access cover	600mm diameter
Approximate weight	45kg (excluding plumbing and pump)

Available in

- BIA-ICON600 Tank only
- BIA-ICON600 Tank with single free standing plumbing
- BIA-ICON600 Tank with single plumbing and guide rails
- BIA-ICON600 Tank with dual free standing plumbing
- BIA-ICON600 Tank with dual plumbing and guide rails

Tanks are supplied as standard with polyethylene lids and are available with lid options as follows:

- > Class B
- > Class D
- > Storm Water grate

900L Polyethylene Pump Station

Model No	BIA-ICON900
Depth	1210mm (excluding lid)
Diameter	1200mm
Access cover	600mm diameter
Approximate weight	55kg (excluding plumbing and pump)

Available in

- BIA-ICON900 Tank only
- BIA-ICON900 Tank with single free standing plumbing
- BIA-ICON900 Tank with single plumbing and guide rails
- BIA-ICON900 Tank with dual free standing plumbing
- BIA-ICON900 Tank with dual plumbing and guide rails

Tanks are supplied as standard with polyethylene lids and are available with lid options as follows:

- > Class B
- > Class D
- > Storm Water grate

1200L Polyethylene Pump Station

Model No	BIA-ICON1200
Depth	1610mm (excluding lid)
Diameter	1200mm
Access cover	600mm diameter
Approximate weight	75kg (excluding plumbing and pump)

Available in

- BIA-ICON1200 Tank only
- BIA-ICON1200 Tank with single free standing plumbing
- BIA-ICON1200 Tank with single plumbing and guide rails
- BIA-ICON1200 Tank with dual free standing plumbing
- BIA-ICON1200 Tank with dual plumbing and guide rails

Tanks are supplied as standard with polyethylene lids and are available with lid options as follows:

- > Class B
- > Class D
- > Storm Water grate

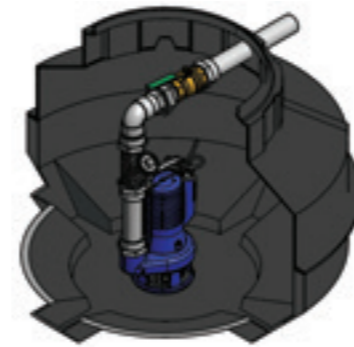

Risers are available as an optional extra (550mm).

Inlet plumbing to be installed by plumber on site.

Applications

- Raw sewage
- Trade Waste
- Effluent
- Storm Water

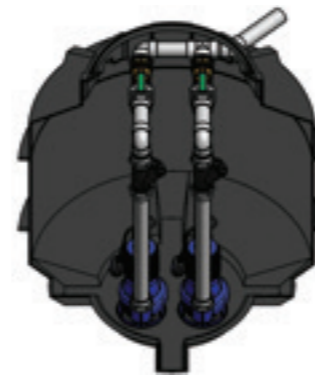

Risers are available as an optional extra (550mm).

Inlet plumbing to be installed by plumber on site.

Applications

- Raw sewage
- Trade Waste
- Effluent
- Storm Water

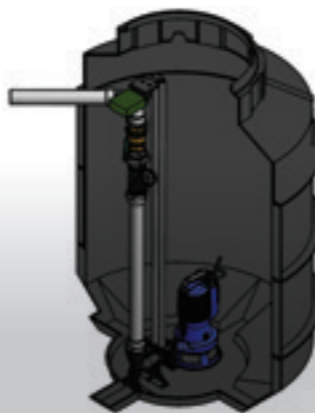

Risers are available as an optional extra (550mm).

Inlet plumbing to be installed by plumber on site.

Applications

- Raw sewage
- Trade Waste
- Effluent
- Storm Water



2700L Polyethylene Pump Station

Model No	BIA-ICON2700
Depth	1690mm (excluding lid)
Width	1565mm
Length	2080mm
Access cover	600mm
Approximate weight	130kg (excluding plumbing and pump)

Available in

- BIA-ICON2700 Tank only
- BIA-ICON2700 Tank with single free standing plumbing
- BIA-ICON2700 Tank with single plumbing and guide rails
- BIA-ICON2700 Tank with dual free standing plumbing
- BIA-ICON2700 Tank with dual plumbing and guide rails

Tanks are supplied as standard with polyethylene lids and are available with lid options as follows:

- > Class B
- > Storm Water grate

Risers are available as an optional extra (550mm).

Inlet plumbing to be installed by plumber on site.

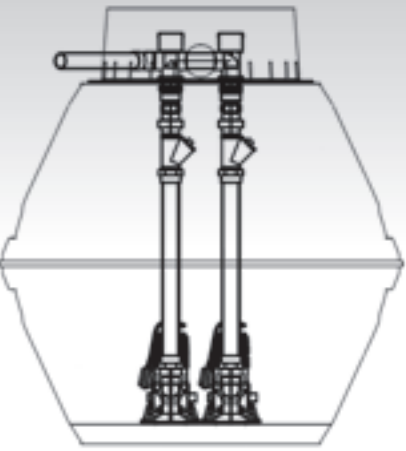

Applications

- Raw sewage
- Trade Waste
- Effluent
- Storm Water

3750L Polyethylene Pump Station

Model No	BIA-ICON3750
Depth	1880mm (excluding lid)
Width	1788mm
Length	2280mm
Access cover	600mm
Approximate weight	160kg (excluding plumbing and pump)

Available in

- BIA-ICON3750 Tank only
- BIA-ICON3750 Tank with single free standing plumbing
- BIA-ICON3750 Tank with single plumbing and guide rails
- BIA-ICON3750 Tank with dual free standing plumbing
- BIA-ICON3750 Tank with dual plumbing and guide rails

Tanks are supplied as standard with polyethylene lids and are available with lid options as follows:

- > Class B
- > Storm Water grate

Risers are available as an optional extra (550mm).

Inlet plumbing to be installed by plumber on site.

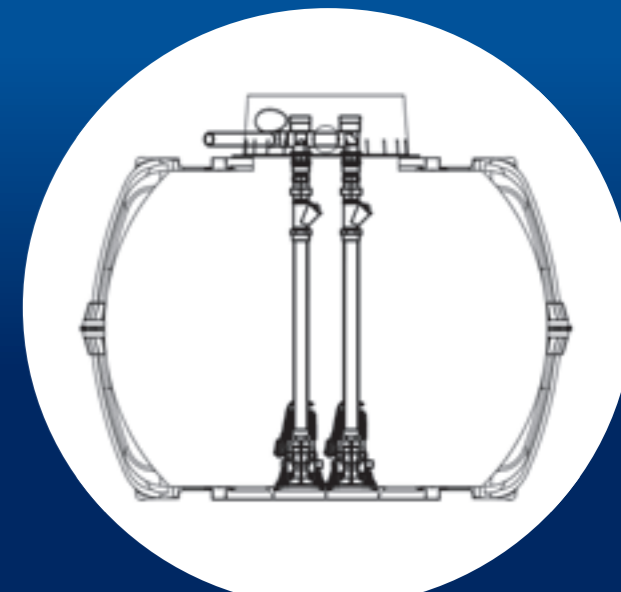

Applications

- Raw sewage
- Trade Waste
- Effluent
- Storm Water